

decrease reaches only 0.3. It is for this reason that the entropy removed above 1.05° is only 0.21 e.u. in the present case. In the second place, Geballe and Giaque made very careful tests for energy absorption in a 60-cycle field, and found none at temperatures as low as 0.24°K. This is in contrast to the absorption of energy from a 400 cycle field by the present substance below 1.18°K. Finally, the decrease in  $\chi_m T$  with decreasing temperature is much less rapid above 2°K. and much more rapid below 2° than was observed with the sulfate. The resemblance between the two substances in position and magnitude of the heat capacity peak above 1°K. appears to be more coincidence than any fundamental phenomenological resemblance.

The energy absorption in the 400 cycle field was obviously due to a relaxation effect with a relaxation time near 1°K. of the order of a millisecond. It was accompanied by a corresponding decrease in the zero-field dynamic susceptibility ( $\chi'$ ) at 400 cycles below the static susceptibility ( $\chi_0$ ) measured by the fluxmeter. This decrease was about 5% at 1.03°K. Using a Debye-type relation between the real component of the susceptibility ( $\chi'$ ) and the imaginary part ( $\chi''$ ),<sup>6</sup> one obtains an estimate of  $\chi''$  as about 0.20 $\chi_0$  under these conditions. Estimates of the average value of  $\chi''$  from the energy absorption during the two magnetizations which started near 1°K. also gives  $\chi'' \approx 0.20\chi_0$ . This agreement may be fortuitous but is not surprising since the specimen was at or near zero field and the lowest temperature during most of the time the 400 cycle field was on.

On the basis of present evidence, we can do little more than speculate on the causes of the observed behavior. The sharpness of the observed heat capacity maximum makes it likely that the effect is cooperative in nature; the relatively low maxi-

(6) See C. J. Gorter, "Paramagnetic Relaxation," Elsevier Press, New York, N. Y., 1947, p. 24.

mum would argue for a highly degenerate (or nearly degenerate) lower state (or states). The relaxation observed below 1.18°K. is reminiscent of the effects observed in the free radical triphenylmethyl<sup>7</sup> and is quite different from the highly reversible behavior of copper salts such as  $\text{CuSO}_4 \cdot 5\text{H}_2\text{O}$ .<sup>5</sup> It is possible that the "transition" at 1.25°K. marks the attainment of energies low enough to permit delocalization of the unpaired electron or cooperative pairing of d-electrons between molecules leading to a highly degenerate ground state. It is our belief that at very low temperatures large groups of molecules act cooperatively, tied together by exchange forces between their electrons.

It is evident that this substance will provide fruitful material for additional measurements, and different types of measurement, at temperatures below those which are reported here.

The lattice heat capacity shows the sort of behavior observed with previous substances.<sup>1,4</sup> The "constant" in the expression  $C_{\text{lattice}} = aT^3$  is  $5 \times 10^{-4}$  at 18-20°K., rises gradually to  $11 \times 10^{-4}$  at 10°K. and remains constant at lower temperatures. A rather similar behavior was observed with copper tetrammine sulfate,<sup>1</sup> but in that case the lower end of the lattice heat capacity curve was obscured by a much higher magnetic heat capacity above 3°K.

**Acknowledgments.**—We wish to thank Mr. L. F. Shultz for production of the refrigerants used and Dr. R. V. G. Rao and Mr. L. Gregor for help in the measurements and calculations. We thank Prof. J. G. Aston for suggesting investigation of this compound and for helpful discussions. We gratefully acknowledge funds provided by the Research Corporation and the Westinghouse Electric Corporation for contribution of the iron-free solenoid magnet. The research described herein was partially supported by funds from the National Science Foundation.

(7) S. I. Weissman, *THIS JOURNAL*, **79**, 5584 (1957). UNIVERSITY PARK, PENNA.

[CONTRIBUTION FROM THE CHEMISTRY DIVISION, ARGONNE NATIONAL LABORATORY]

## Chemical Effects of Atomic Hydrogen in Aqueous Solutions<sup>1</sup>

BY THOMAS W. DAVIS, SHEFFIELD GORDON AND EDWIN J. HART

RECEIVED FEBRUARY 19, 1958

Evidence has been obtained for the oxidation of ferrous ions in sulfuric acid solution by hydrogen atoms. The hydrogen atoms were produced externally and circulated through the cell containing the ferrous ions. On the basis of these results and the non-chain character of the  $\gamma$ -ray induced water-deuteration reaction, the authors conclude that oxidation is not through  $\text{H}_2^+$ . Two mechanisms proposed are:  $\text{H} + \text{H}^+ + \text{Fe}^{++} = \text{H}_2 + \text{Fe}^{+++}$  and  $\text{H} + \text{Fe}^{++} \cdot (\text{H}_2\text{O})_n = \text{H}_2 + \text{Fe}^{+++} \cdot (\text{H}_2\text{O})_{n-1} + \text{OH}^-$ .

As late as 1950, the basic free radical reactions of the radiation promoted oxidation of acidic air-free ferrous sulfate solutions were uncertain. The stoichiometry of this reaction is closely approximated by equation 1<sup>2</sup>

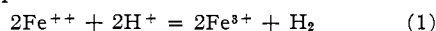

Hydrogen formation is equivalent to ferric ion formation.

(1) Based on work performed under the auspices of the U. S. Atomic Energy Commission.

(2) H. Fricke and E. J. Hart, *J. Chem. Phys.*, **3**, 60 (1935).

Weiss<sup>3</sup> suggests participation of a hypothetical hydrated hydrogen molecule ion formed from a hydrogen atom and a hydrogen ion in the oxidation step as

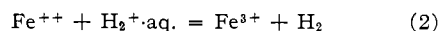

Reaction 2 followed by 3 therefore accounts for the stoichiometry observed in 1

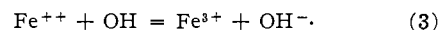

(3) J. Weiss, *Nature*, **165**, 728 (1950).

Studies<sup>4</sup> on the radiolysis of dilute aqueous formic acid led to the conclusion that each hydrogen atom reacts with formic acid to liberate a molecule of hydrogen gas. In view of the equivalence of hydrogen and ferric ions in reaction 1 and the close agreement of hydrogen yields in the formic acid and air-free ferrous sulfate radiolyses, it was concluded that hydrogen atoms oxidize ferrous ions in 0.8 *N* sulfuric acid.<sup>5</sup> The reaction assumed is

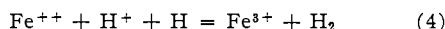

Direct experimental evidence supporting reactions 2 and/or 4 was sought in 1950. Attempts to oxidize ferrous ions at the cathode in rapidly stirred deaerated solutions of ferrous sulfate were unsuccessful.<sup>6</sup> But experiments carried out using rapidly circulating hydrogen and argon in a discharge tube were more successful. By bubbling the electrically dissociated products through oxygen-free ferrous sulfate, oxidation occurred whereas dilute aqueous silver sulfate solutions were reduced. Recently these exploratory experiments have been confirmed by using hydrogen atoms generated by thermal as well as electrical dissociation. This new evidence, supporting equation 4, is given in this paper.

### Apparatus and Procedure

Monatomic hydrogen is generated in a water-cooled discharge tube having water cooled chromium plated electrodes, operating at a potential of 2000–3000 volts (see A of Fig. 1). The inside wall of the 100 cm. × 3.0 cm. diameter tube is poisoned by phosphoric acid solution and the exit tube (B) leading to the solution is poisoned by sulfuric acid or phosphoric acid. A mercury diffusion pump (C) of the design recommended by Harteck and Roeder<sup>7</sup> pumps the discharge gases (usually at 15 mm. pressure) through the tube and solutions at a rate of about 1.5 liters sec.<sup>-1</sup>. Mercury and water vapors are removed from the circulating gases before re-entry to the discharge tube by passage through three traps (D, E, F) cooled by liquid nitrogen. Hydrogen is introduced through a heated palladium thimble (G) after the apparatus is pumped to 10<sup>-6</sup> mm. mercury pressure. Argon is admitted later after passage over uranium filings heated to 800° in furnace (H). These treatments are used to remove traces of oxygen from the circulating gases.

In a typical experiment with the apparatus of Fig. 1, syringe (I) containing about 100 ml. of deaerated solution

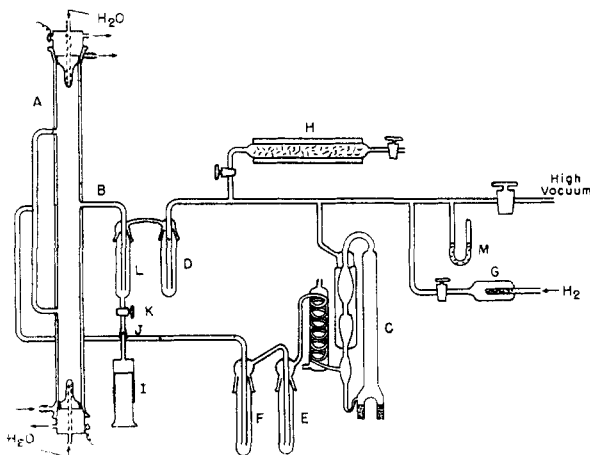

Fig. 1.—Electrical dissociation assembly.

(4) E. J. Hart, *THIS JOURNAL*, **73**, 68 (1951).

(5) E. J. Hart, unpublished data, Jan. 27, 1950.

(6) Ref. 5, June–Sept., 1950.

(7) P. Harteck and E. Roeder, *Z. Elektrochem.*, **42**, 536 (1938).

is attached to the system at the 5/30 standard taper joint (J). Next, a small amount of solution is introduced into the evacuated system through the stopcock (K) in order to remove air from these parts. The system is then pumped down to 10<sup>-6</sup> mm. mercury. Then the purified hydrogen and argon are added to the desired pressures as indicated on mercury manometer (M). The arc in the discharge tube (a) is then struck and the system freed from impurities by rapid circulation of the gases by the high speed diffusion pump through liquid nitrogen traps (D, E and F). After a one minute cleaning up period, 10 ml. of the degassed solution from syringe (I) is transferred to the reaction vessel (L) while the discharge tube is still operating. Rapid passage of the discharge gases through the solution is maintained during irradiation and provides turbulent agitation. After irradiation, the solution is withdrawn from cell (L) into an evacuated bulb attached to the system at (J).

A thermal dissociation apparatus patterned after the one described by Kroepelin, Vogel and Kremser<sup>8</sup> is also used to generate atomic hydrogen. This apparatus with attached cell assembly is shown in Fig. 2. We use the same circulation system and gas purification techniques as before. The purified hydrogen passes over the tungsten spiral at temperatures of 2000–2400°. This temperature is determined from the electrical resistance of the wire and checked by an optical pyrometer. When we generate hydrogen atoms thermally, we eliminate long lived excited molecules or radicals. In addition, we feel that the poisoned surface of this apparatus is less likely to generate phosphine or hydrogen sulfide during operation than does the surface of the discharge tube.

The inner surface of the dissociation cell (A of Fig. 2) and the exit-tube (B) are poisoned with dilute phosphoric acid.<sup>8</sup> Then these surfaces are heated with a hot gas-oxygen flame until an insoluble white poisoned surface is obtained.

In our first experiments the dissociated gases are bubbled through the solution as described for the apparatus of Fig. 1. In later experiments, the degassed solutions flow upward through capillary (C) and drain down over its outer surface. The down sweeping gases from the thermal dissociation unit (A) contact the solution at the end and sides of this vertical capillary tube. The irradiated solution is then collected in detachable bulb (D).

Ferrous ion is estimated in ferric solutions by the *o*-phenanthroline method and measuring light absorption at 5100 Å. Ferric ion is determined in ferrous sulfate solutions by light absorption at 3020 Å.

All solutions are prepared from "Reagent" grade chemicals in triply distilled water.<sup>8</sup>

### Results and Discussion

**A. Electrical Dissociation Experiments.**—The discharge tube yields monatomic hydrogen when a discharge passes through a gas consisting of argon (pressures of 10–20 mm.) and hydrogen (0.5–1.0 mm.). (The H  $\alpha$  lines are visible with a hand

(8) H. Kroepelin, E. Vogel and G. Kremser, *Abhandl. braunschweig wiss. Ges.*, **6**, 73 (1954).

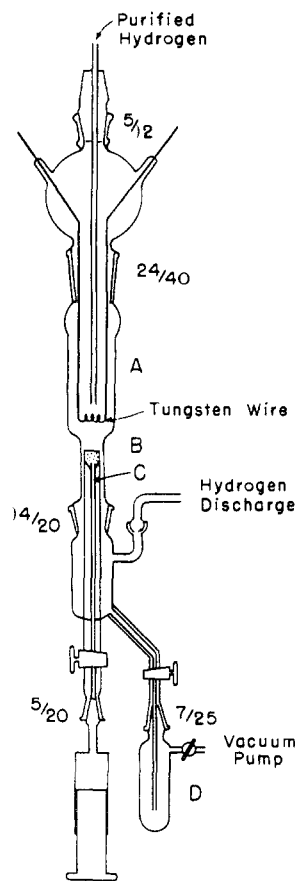

Fig. 2.—Thermal dissociation assembly.

spectrograph.) The gases leaving the discharge cause (1) strong heating of the tube leading to the reaction vessel, (2) blackening of a bead of molybdenum trioxide, (3) reduction of ferric sulfate solution (with or without formic acid), (4) reduction of ceric sulfate solution and (5) reduction of sulfuric acid to hydrogen sulfide. In view of these tests, we conclude that appreciable concentrations of hydrogen atoms are available for reaction in the irradiation cell.

The discharge gases cause reduction of ferric sulfate solution ( $\sim 2.2$  mN) in 0.01 N sulfuric acid in amounts of 0.83, 1.0, 7.0 and  $< 0.1$   $\mu$ equiv. min.<sup>-1</sup> in four different experiments; 1.5  $\mu$ equiv. min.<sup>-1</sup> of ferric sulfate is reduced in 0.8 N sulfuric acid. Under the conditions of these experiments, a concentration change of 0.01  $\mu$ equiv. can be measured. Reduction of ceric sulfate solution occurs at a rate of 0.25  $\mu$ equiv. min.<sup>-1</sup>. Reproducibility is poor, probably because of metallic contamination on the walls of the discharge tube. Littman, Carr and Brady<sup>9</sup> found it necessary to clean the discharge tube thoroughly before each run in order to maintain a reproducibility of  $\pm 10\%$ .

Our discharge gases capable of reducing ferric sulfate oxidize 2 mN ferrous sulfate solutions in 0.8 N sulfuric acid at the following rates: 0.64, 0.78, 1.7 and 1.25  $\mu$ equiv. min.<sup>-1</sup>. Hydrogen sulfide, detected by its odor, also forms.

With greater concentration of ferrous sulfate, oxidation occurs more rapidly; 100 mN ferrous sulfate in 0.8 N sulfuric acid is oxidized in experiments lasting 2 and 5 min., at the rates 5.8 and 8.0  $\mu$ equiv. min.<sup>-1</sup>, respectively. The last result suggests one possible source of the variation in chemical yields from one experiment to another. Only part of the atoms in the gas stream reaching the solution, we believe, react with the solute.

In several instances, the target solutions are heated by means of electrical resistance tape. In a typical series, the heated solutions, which average 10° warmer than the unheated solutions, undergo reaction two to six times as fast as the unheated ones.

The effect of adding formic acid to ferric sulfate solution is shown by experiments 3 and 4 of Table I. The formic acid acts as a hydrogen atom scavenger and thus reduces more ferric sulfate.

The gases from an electrical discharge through water vapor contain H-atoms and OH-radicals. They oxidize or reduce compounds.<sup>10</sup> While the results quoted above show the oxidizing abilities of H-atoms in acidic ferrous sulfate solutions, we must also consider the effects of water in the discharge gases. The water may come from the phosphoric acid introduced as an anticatalytic layer on the surface of the discharge tube or it might be carried as fog from the reactive solutions. We reduced the water content of the circulating gases by placing activated charcoal in Trap (F) (Fig. 1). At -78° argon, without added hydrogen, effected a slow oxidation of 2 mN ferrous sulfate in 0.8 N sulfuric acid and a slow reduction of 10 mN ferric sulfate in 0.01 N sulfuric acid. (See Table I, exp. 1 and 2, resp.)

(9) F. E. Littman, E. M. Carr and A. P. Brady, *Radiation Research*, **7**, 107 (1957).

(10) G. I. Lavin and F. B. Stewart, *Nature*, **123**, 607 (1929).

TABLE I  
OXIDATION OF FERROUS SULFATE AND REDUCTION OF FERRIC SULFATE BY ELECTRICALLY DISSOCIATED HYDROGEN ATOMS

Code no.	Fe(SO <sub>4</sub> ) <sub>2</sub> , mN	(Fe <sub>2</sub> (SO <sub>4</sub> ) <sub>3</sub> ), mN	(H <sub>2</sub> SO <sub>4</sub> ), N	(HC-OOH), mM	$\mu$ equiv. Fe <sup>++</sup> or Fe <sup>3+</sup> /min. Discharge gas	
					Argon	Argon + H <sub>2</sub>
A. Gases passed through charcoal at -78°						
1	2.0	..	0.8	..	0.21; 0.60	0.90; 0.85
2	..	10.0	.01	..	.16	..
B. Gases passed over 14 N H <sub>2</sub> SO <sub>4</sub> at -78°						
3	..	2.0	0.01	..	..	1.7
4	..	2.0	.01	10	..	3.0; 3.8; 3.9
5	..	2.0	.01	100	..	4.9
6	..	10.0	.01	..	1.2	2.8; 5.3 <sup>a</sup>
C. Gases passed over 14 N H <sub>2</sub> SO <sub>4</sub> at 25°						
7	..	2.0	0.01	..	..	1.1
8	2.0	..	.8	..	12; 36	..
9	..	..	..	..	5.0 <sup>b</sup>	0.19 <sup>b</sup>
10	1 mM H <sub>2</sub> O <sub>2</sub>	..	..	..	..	0.9 <sup>c</sup>

<sup>a</sup> Solution heated during 2 minute irradiation. <sup>b</sup>  $\mu$ moles H<sub>2</sub>O<sub>2</sub> per minute obtained in triply distilled water. <sup>c</sup>  $\mu$ moles H<sub>2</sub>O<sub>2</sub> per minute (decomposition).

To test the effect of water vapor, we replaced the charcoal Trap (F) by 14 N sulfuric acid. Now, when the circulating argon (with no added hydrogen) passes over this acid solution at -78°, a larger amount of water vapor is brought into the arc and a more rapid reaction takes place in the target solution. (Compare exp. 2 and 6 of Table I.) When the argon is humidified by passage over 14 N sulfuric acid at room temperature, ferrous sulfate (2 mN Fe<sup>++</sup> in 0.8 N H<sub>2</sub>SO<sub>4</sub>) is oxidized at a much larger rate. (Compare exp. 1 and 8 of Table I.) This most highly humidified argon, after passing through the discharge, deposits peroxide in a target liquid composed initially only of distilled water at a rate comparable with the rate of oxidation of ferrous sulfate (exp. 9).

The addition of hydrogen in normal proportions to the circulating argon alters the effects noted above, some of them very drastically. In particular, added hydrogen lowers the rate of formation of hydrogen peroxide and increases the rate of reduction of ferric solution and the rate of oxidation of ferrous solution (see Table I).

**B. Thermal Dissociation Experiments.**—In these experiments, the formation of hydroxyl radicals from water cannot be serious. Hydrogen is not recirculated and water cannot be drawn from the highly dehydrated anticatalytic layer on the silica walls of the dissociation apparatus. Furthermore, when water vapor or a source of oxygen is brought into contact with the heated tungsten spiral, a deposit of tungsten oxide distills to the cold walls. No transfer takes place during the runs reported in Tables II and III. Furthermore, less than a few parts per hundred thousand of carbon dioxide and oxygen is found, by mass spectrometer analysis, in the hydrogen. Besides, if O-atoms or OH radicals are created in the hydrogen stream, they will react with the large excess of molecular hydrogen in the region between the coil and the solution since the transport time is of the order of milliseconds. In view of these tests and reasoning, we believe that oxygen-containing radicals are absent.

TABLE II  
REDUCTION OF FERRIC SULFATE BY THERMALLY DISSOCIATED HYDROGEN ATOMS

Code no.	Fe <sub>2</sub> (SO <sub>4</sub> ) <sub>3</sub> , mN	H <sub>2</sub> SO <sub>4</sub> , N	Type reaction vessel <sup>a</sup>	μequiv. Fe <sup>++</sup> /min.
1	1.0	0.01	Bubbler	0.31; 0.10
2	1.0	.01	Capillary	1.35; 3.4 <sup>b</sup>
3	1.0	.01	Capillary	0.42; 0.26
4	10.0	.01	Bubbler	0.23
5	1.0	.02	Capillary	0.74 <sup>c</sup> ; 0.24
6	1.0	.8	Bubbler	0.06
7	2.0	.8	Capillary	0.11; 0.10; 0.10

<sup>a</sup> Bubbler and capillary type cells are shown in Figs. 1 and 2, respectively. <sup>b</sup> 20 second exposure. <sup>c</sup> 60 second exposure (exposures are usually 5 to 10 min.).

TABLE III  
OXIDATION OF FERROUS SULFATE BY THERMALLY DISSOCIATED HYDROGEN ATOMS

Exp. no.	FeSO <sub>4</sub> , mN	H <sub>2</sub> SO <sub>4</sub> , N	NaCl, mM	Type reaction vessel <sup>a</sup>	μequiv. Fe <sup>+++</sup> /min.
1	1.0	0.01	..	Bubbler	0.25
2	1.0	.8	..	Bubbler	0.57; 0.08; 0.10
3	1.0	.8	..	Bubbler	.02; .60; .07
4	1.0	.8	..	Bubbler	.02; .01; .01
5	1.0	.8	1.0	Bubbler	.09; .06
6	10.0	.8	..	Bubbler	0.93
7	1.0	.8	1.0	Capillary	0.11; 0.25; 0.27
8	1.0	.8	1.0	Capillary	1.6 <sup>b</sup>
9	1.0	.8	1.0	Capillary	0.02; 0.23; 0.35
10	100.0	.8	..	Capillary	1.23

<sup>a</sup> Bubbler and capillary type cells are shown in Fig. 1 and Fig. 2, respectively. <sup>b</sup> 40 second irradiation. Hydrogen sulfide is produced in exp. 7-10, incl.

These gases reduce 1 mM ferric sulfate at a rate of 0.68 μmole min.<sup>-1</sup> and they reduce 0.56 mM hydrogen peroxide solution at a rate of 0.025 μmole min.<sup>-1</sup>. Ferrous sulfate is also oxidized at rates averaging 0.2 μmole min.<sup>-1</sup> (see Table III). These exposures are for 3 to 9 minute duration.

We find that only a small fraction of the yields given in Tables II and III is caused by light. When hydrogen is replaced by helium in the thermal dissociation apparatus, very little chemical effect is found.

The variation in the yields from one experiment to the next are not related in any systematic way to the temperature of the coil, hydrogen pressure, the rate of gas flow, nor to the time of exposure. Large variations in hydrogen atom concentrations from one run to the next are also found by our calorimetric measurements. These runs are made with a calorimeter of the Kroepelin, Vogel and Kremser design.<sup>8,11</sup>

The technique of passing atomic hydrogen from a hot coil through or over solutions does not lead to measurements of high precision. More oxidation, for example, occurs in solutions of high ferrous ion concentration than in solutions of low concentration. And the rate of oxidation of ferrous ions is

(11) In a typical calorimeter run, we pass hydrogen at the rate of 11 l. min.<sup>-1</sup> at 25 mm. pressure over the tungsten wire heated to 2200°K. From the rate of increase in temperature of the calorimeter, we calculate a hydrogen atom yield at the surface of the liquid of 360 μmoles of hydrogen atoms per minute. This concentration of hydrogen atoms reduces 0.68 μmole min.<sup>-1</sup> of ferric ions in a 1mM solution of ferric sulfate indicating an efficiency of less than 1% for reduction under our experimental conditions.

of the same order of magnitude as the rate of reduction of ferric ions under comparable experimental conditions. Since the gases from the coil have a net reducing action on ferric sulfate and on hydrogen peroxide solutions, they must contain an excess of atomic hydrogen.

Consequently, we attribute the oxidation of ferrous sulfate in 0.8 N sulfuric acid to hydrogen atoms as is concluded from radiation chemistry studies of this system. Note that ferrous ions are oxidized in a strongly reducing medium since sulfuric acid is simultaneously reduced to hydrogen sulfide.

This formation of hydrogen sulfide has not been reported in sulfuric acid radiolysis by γ-rays. Only in very concentrated solutions (60%) is the acid appreciably affected<sup>12</sup> by irradiation, and then to form sulfur dioxide. The H-atoms and OH radicals when produced in nearly equal quantity during the radiolysis of water leave dilute sulfuric acid unaffected. Introduction of equal proportions of the two species, H and OH, from an outside source, likewise, must leave the sulfuric acid unaffected. Since hydrogen sulfide is found, we must have a much greater number of hydrogen atoms than hydroxyl radicals in the gas stream emerging from our discharge tube or from the heated tungsten spiral. Harteck and Stewart<sup>13</sup> also report hydrogen sulfide from the reaction of hydrogen atoms with thiosulfate ions.

The oxidation of ferrous ion by hydrogen atoms may be explained by the H<sub>2</sub><sup>+</sup> complex of reaction 2 or by an equivalent triple collision shown in reaction 4. It is difficult to assess the relative importance of these two reactions in our experiments.

Evidence supporting reaction 4 rather than 3 is provided by the absence of a chain reaction for HD formation in water containing dissolved deuterium.<sup>14,15</sup> G(HD) is 3.3 which is equal to the yield of hydrogen atom formation of γ-rays in acid solutions. This shows that a chain reaction is not set up between deuterium atoms and hydrogen ions to form hydrogen atoms. The reactions of hydrogen atoms and hydroxyl radicals with dissolved deuterium are

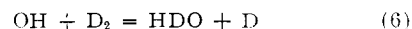
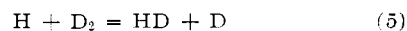

If the equilibrium

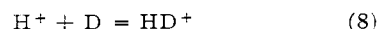

exists as is required for H<sub>2</sub><sup>+</sup> formation in reaction 2, as postulated by Weiss, then the reverse reaction will yield hydrogen atoms

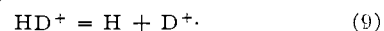

The net reaction of 8 and 9 is

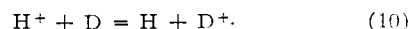

Once D<sup>+</sup> is formed, it can no longer participate in the reverse reaction because of the high hydrogen

(12) C. J. Hochanadel, J. A. Ghormley and T. J. Sworski, *THIS JOURNAL*, **77**, 3215 (1955).

(13) P. Harteck and K. Stewart, *Z. physik. Chem.*, **A181**, 183 (1937).

(14) S. Gordon and E. J. Hart, *THIS JOURNAL*, **77**, 3981 (1955).

(15) H. L. Friedman and A. H. Zeltman, *J. Chem. Phys.*, **28**, 878 (1958).

ion concentration. Therefore, exchange will be complete. We now expect  $G(\text{HD})$  to increase by a chain propagation sequence consisting of steps 5, 8 and 9 as the  $p\text{H}$  is lowered. No such increase is found<sup>15,16</sup> and we conclude that  $\text{HD}^+$  does not play a role in the water-deuterium exchange reaction.

Owing to the hydration of  $\text{H}_2^+$ , we expect this ion to have high solubility in water compared to hydrogen atoms. On this basis, more chemical effect will occur at lower  $p\text{H}$ s. Still the rate of hydrogen atom reduction of ferric ions in 0.01  $N$  sulfuric acid is about the same as the rate of oxidation of ferrous ions in 0.8  $N$  sulfuric acid. And the  $\gamma$ -ray reduction yield of ferric ions by hydrogen atoms is equal to the  $\gamma$ -ray oxidation yield of ferrous ions by hydrogen atoms. Therefore the hydrogen atom concentration is not appreciably altered by  $p\text{H}$ .

On the basis of the above evidence, we favor reaction 4 involving a triple collision of ferrous ion, a hydrogen atom and a hydrogen ion for explaining the oxidation of ferrous ions by hydrogen atoms.

An alternate mechanism is the reaction of the hydrogen atom with a polarized water molecule in the hydration sphere of the ferrous ion.

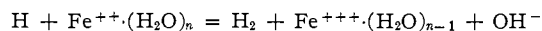

This is consistent with photochemical evidence.<sup>16</sup>

**Acknowledgments.**—We gratefully acknowledge help from Miss P. D. Walsh for analytical data and from Messrs. Joseph Hodur and Peter Ziegelmeir for glass-blowing and machine work.

(16) M. Lefort and P. Douzou, *J. chim. phys.*, **69**, 536 (1956).

LEMONT, ILLINOIS

[CONTRIBUTION FROM THE NATIONAL LEAD COMPANY, INC., A.E.C. RAW MATERIALS DEVELOPMENT LABORATORY]

## A Spectrophotometric Investigation of Vanadium(V) Species in Alkaline Solutions<sup>1</sup>

BY LEONARD NEWMAN,<sup>2</sup> WILLIAM J. LAFLEUR, FREDERICK J. BROUSAIDES AND ARTHUR M. ROSS

RECEIVED FEBRUARY 27, 1958

The interpretation of spectrophotometric data has demonstrated that both monohydrogen orthovanadate and pyrovanadate are formed during the first break in the titration of orthovanadate with acid. A constant of  $0.097 \pm 0.005$  has been obtained at 25° for the hydrolysis of orthovanadate to monohydrogen orthovanadate at an ionic strength of 3.0 over the ranges in vanadium concentration of  $2 \times 10^{-4} M$  to  $1 \times 10^{-2} M$ , hydroxide concentration of 0.01 to 3.0  $M$  and wave length of 260 to 360  $m\mu$ . A constant of  $48 \pm 5$  has been obtained for the dimerization of monohydrogen orthovanadate to pyrovanadate over the ranges in vanadium concentration of 0.01 to 0.1  $M$  and hydroxide concentration of 0.0015 to 0.01  $M$ .

The chemistry of vanadium(V) has been the subject of many investigations over a period of more than fifty years. It has been shown that when a solution of orthovanadate is titrated with acid, three inflections, or breaks, are observed in the plotted curve. All workers in the field agree that the first two breaks appear, respectively, upon the addition of one and two equivalents of acid. However, there is some disagreement as to the number of equivalents required for the third break; some workers report it as 2.5 equivalents, while others report it as 2.6 equivalents.

Of chief interest in the present investigation has been a quantitative understanding of the chemistry of vanadium in highly alkaline media, covering the  $p\text{H}$  region involved when the first equivalent of acid is added to orthovanadate. No conclusive data were available; some workers postulated that monohydrogen orthovanadate is formed in this  $p\text{H}$  region, others suggested that pyrovanadate is formed, and still others concluded that both species are formed. Nearly all these workers relied on titrimetric and/or cryoscopic measurements basing their decisions solely on the stoichiometry. It was clearly evident that any effort to enlarge or improve on such measurements would not be likely to provide a singular solution to the problem. The adoption of a different approach was most desirable and accordingly it was decided to study the vanadium

species by a spectrophotometric method. The appropriate spectrophotometric equations are derived and utilized in a manner similar to that described by Newman and Hume.<sup>3</sup>

**Reagents and Instruments.**—Fisher Scientific Company purified sodium orthovanadate was used as a source of vanadium, and Fisher Scientific Company purified sodium perchlorate monohydrate as a source of perchlorate. All other chemicals were reagent grade.

A Beckman model DU quartz spectrophotometer equipped with a hydrogen lamp was used for all spectrophotometric measurements. Matched one-centimeter cells were used throughout.

A Beckman Model G  $p\text{H}$  meter was used equipped with a Beckman Type E-2 glass electrode to avoid  $p\text{H}$  errors in the highly alkaline region.

### Data and Results

**Hydrolysis of Orthovanadate.**—When sodium orthovanadate is dissolved in water, about half of it hydrolyzes.<sup>4</sup> Two equally possible hydrolysis reactions can be postulated

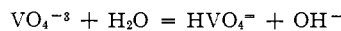

and

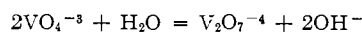

The basis of the present method of investigation has been to add first a sufficiently great excess of hydroxide to repress the hydrolysis so that less than 5% of the orthovanadate is hydrolyzed, then to decrease slowly the hydroxide concentration to permit further hydrolysis to take place. From a meas-

(1) This work was done under U. S. Atomic Energy Commission Contract No. AT(49-6)-924 and was presented at the 133rd Meeting of the American Chemical Society in San Francisco, Calif., April, 1958.

(2) Address all correspondence to L. Newman, Brookhaven National Laboratory, Associated Universities, Inc., Upton, New York.

(3) L. Newman and D. N. Hume, *THIS JOURNAL*, **79**, 4571, 4576, 4581 (1957).

(4) H. T. S. Britton and R. Robinson, *J. Chem. Soc.*, 1261 (1930); 1955 (1932); 512 (1933).